

1254

TWELVE FIFTY FOUR INDUSTRIES

STEEL NON TAPERED ROUND 12P-SNTR SERIES POLES

CONSTRUCTION
Poles – Round straight steel poles are formed from hot rolled carbon steel with minimum yield strength of 42,000 psi. **Base Plate** – The base plate conforms to ASTM A36. The base plate telescopes onto the pole base then gets welded circumferentially on top and bottom. **Anchor Bolts** – Anchor bolts are fabricated from carbon steel round bar and conform to ASTM F1554. Bolts have an “L” bend on one end and are galvanized in accordance with ASTM-A-153. Each anchor bolt is furnished with two hex nuts and two flat washers.

12P-SNTR- 1254 POLES STEEL NON TAPERED ROUND CHART

MODEL NUMBER	SHAFT SIZE O.D. (in) (B)	WALL THK (in) (A)	POLE HEIGHT (H)	BASE PLATE (in)	BASE PLATE THK (in)	BOLT CIRCLE (in)	ANCHOR BOLT SIZE (in)
30012596	3.00	0.125	8	8	0.5	8	.75 x 18 x 3
300125120	3.00	0.125	10	8	0.5	8	.75 x 18 x 3
300125144	3.00	0.125	12	8	0.5	8	.75 x 18 x 3
300125168	3.00	0.125	14	8	0.5	8	.75 x 18 x 3
400125120	4.00	0.125	10	9.5	0.75	9.5	.75 x 18 x 3
400125144	4.00	0.125	12	9.5	0.75	9.5	.75 x 18 x 3
400125168	4.00	0.125	14	9.5	0.75	9.5	.75 x 18 x 3
400125180	4.00	0.125	15	9.5	0.75	9.5	.75 x 18 x 3
400125192	4.00	0.125	16	9.5	0.5	9.5	.75 x 18 x 3
400125216	4.00	0.125	18	9.5	0.5	9.5	.75 x 18 x 3
400125240	4.00	0.125	20	9.5	0.75	9.5	.75 x 18 x 3
400125264	4.00	0.125	22	9.5	0.75	9.5	.75 x 18 x 3
400125288	4.00	0.125	24	9.5	0.75	9.5	1 X 36 X 4
400125300	4.00	0.125	25	9.5	0.75	9.5	1 x 36 x 4
450188240	4.50	0.188	20	9.5	0.75	9.5	.75 x 18 x 3
450188300	4.50	0.188	25	9.5	0.75	9.5	1 X 36 X 4
450188360	4.50	0.188	30	9.5	0.75	9.5	1 x 36 x 5
500125240	5.00	0.125	20	10.5	0.75	10.5	.75 x 18 x 3
500125300	5.00	0.125	25	10.5	0.75	10.5	1 X 36 X 4
500188300	5.00	0.188	25	10.5	0.75	10.5	1 x 36 x 4
500188360	5.00	0.188	30	10.5	0.75	10.5	1 x 36 x 5

TENON MOUNTING

- TM0 - Plain Top
- TM1 - 2.38" O.D. x 3.00"
- TM2 - 2.38" O.D. x 4.00"
- TM3 - 2.88" O.D. x 3.00"
- TM4 - 2.88" O.D. x 4.00"
- TM5 - 3.00" O.D. x 3.00"
- TM6 - 3.00" O.D. x 4.00"
- TM7 - 3.50" O.D. x 3.50"
- TM8 - 3.50" O.D. x 4.00"
- TM9 - 4.00" O.D. x 4.00"
- TM10 - 4.00" O.D. x 6.00"
- TM11 - Other Tenon (Consult Factory)
- AT - 2-3/8" O.D. X 5" long tenon
- BT - 2-7/8" O.D. X 5" long tenon
- CT - 3" O.D X 5" long tenon

Drill Mount



OPTIONS:

- BC - Two piece square base cover
- DR - Duplex recepticle
- GFI - Ground Fault Interruptor
- Other options contact factory

COLOR:

- Polyester powder fuse coating.
- BZ - Bronze
- BK - Black
- GN - Green
- WT - White
- Other colors contact factory

FINISH:

- 12-P1 - 12-PRO-1 1 COAT POWDER OR LIQUID
- 12-P2 - 12-PRO-2 2 COAT POWDER OR LIQUID, PRIMER & TOP COAT
- 12-P3 - 12-PRO-3 2 COAT POWDER OR LIQUID, ZINC PRIMER & PREMIUM TOP COAT
- 12-P4 - 12-PRO-4 2 COAT POWDER OR LIQUID, ZINC PRIMER & PREMIUM TOP COAT
- ANO - Anodize
- ZM - Zinc Metalize
- HDG - Hot Dip Galvanize
- Other options upon request

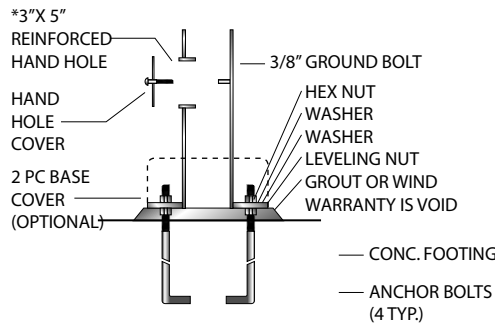
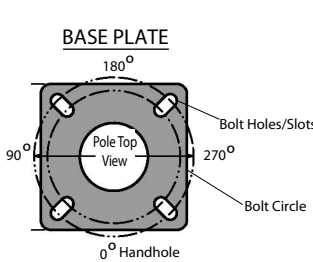
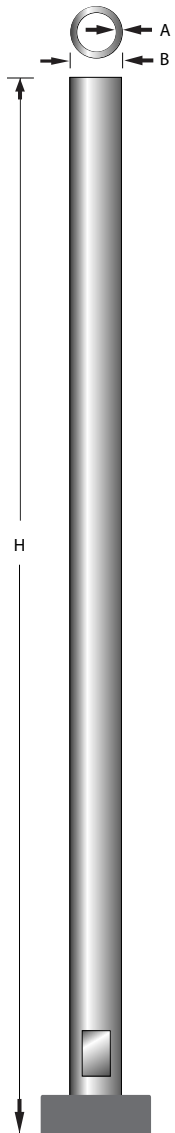

ORDERING LOGIC

POLE SERIES #	POLE MOD #	FIXTURE MOUNTING	OPTIONS	COLOR	FINISH
12P-SNTR					
EXAMPLE BELOW					
12P-SNTR	300125120	BT	BCDR	BK	12P4