

1254

TWELVE FIFTY FOUR INDUSTRIES

INGROUND UPLIGHT

12FX-LS120-185

Product Description

This water tight uplight is designed for in ground use where a flush, or hidden light would be ideal. Constructed of Stainless Steel and PC.

Product Dimensions

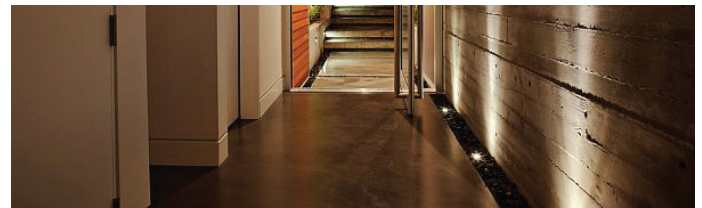
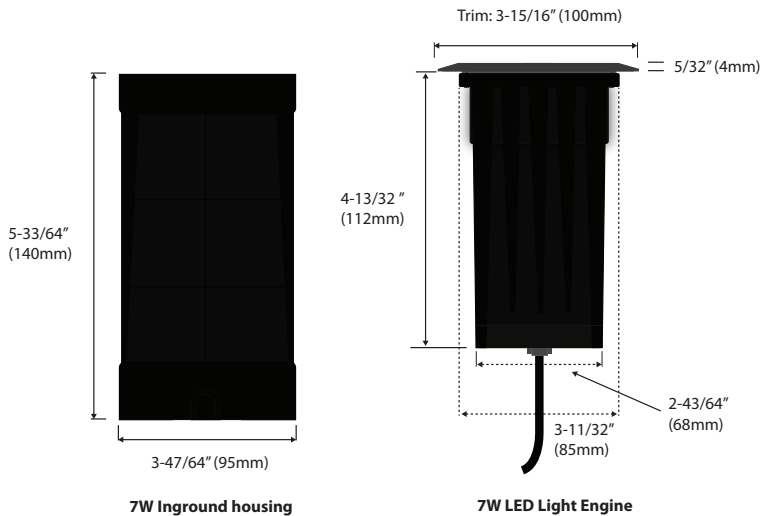

Features & Benefits

- » Excellent for use in inground applications
- » Ideal Uplighting
- » Low power consumption 7W
- » High brightness LED Technology
- » Long lifespan +50,000 hours

Specifications

- » Voltage: 100-130V AC
- » Wattage: 7W
- » # of LEDs: 1 COB
- » Beam Spread: 40°
- » Color Temperature: 5500K
- » Lumen Output: 7W - 620 Lumens
- » IP Rating: 67
- » Working Temperature: -20-- +45°
- » Cover & Housing: Stainless Steel Cover
PC housing

Ordering Information